

YOU CAN TAKE CONTROL

What you can achieve by changing your
everyday habits concerning water



BUNDABERG
REGIONAL COUNCIL



1. Water Pollution

We all use water, we couldn't live without clean water. Every time we use water, we contribute to producing sewage, which in turn can pollute the environment.

WHY IS POLLUTION A PROBLEM?

Plants and animals living in streams, rivers and oceans, rely on water to provide them with oxygen, which is essential for life. Pollutants such as sewage, vegetable and animal waste, silt and detergents can all reduce the amount of oxygen available. Pollutants such as fertilisers, chemicals and oil can directly poison animal and plant life.

HOW IS WATER POLLUTED?

Water pollution can happen when sewage is not effectively treated before it is released into the environment or water becomes polluted by people's activities – littering or dumping. This can happen in many ways, some are accidental but others are deliberate.

WATER POLLUTION

Urban Development

- Building and construction can wash soil into our waterways.
- Rainwater that falls on our houses and roads is carried away in a system of pipes that is separate from the sewerage system. These stormwater drains also collect any litter or other material, including animal droppings. All of this rubbish is generally carried straight into rivers or out to the sea by stormwater drains.
- Stormwater drains are also commonly responsible for carrying spilled toxic chemicals, such as pesticides, detergents, fertilisers, oil and other materials into our waterways.

Industry

Pollution to our waterways can occur through direct discharge and contamination of soil. Industry needs to be careful with the types of waste chemicals and materials that are discharged to the environment. Council has a Trade Waste policy that sets the standard of Industrial Waste allowed into the sewerage system.

Farming and horticulture

Most farmers use a wide range of fertilisers, herbicides, insecticides and other chemicals on their crops and these can run into the waterways. The movement of cattle roaming and grazing on the farm can also cause soil to be washed into the waterways.

People's activities

People's activities such as littering and dumping have a negative effect on our waterways. Also recreational activities such as

- Swimming can stir sediments
- Boating can result in oil spills and erosion of the riverbanks



WHAT ARE THE TYPES OF WATER POLLUTION?

There are many forms of water pollution. Here are just a few of the common ones that you often read about.

- **E.Coli:** These micro-organisms come from animal waste (mainly human) and provide definite evidence of human pollution. The level of E.Coli in the water is used as a guide to indicate the presence of pathogenic or disease-causing bacteria.
- **Toxic chemicals:** Many chemicals used in industry are poisonous to wildlife. Dioxin and heavy metals, such as mercury, are well known examples of the thousands of toxic chemicals produced by industry. Even in very small quantities toxic chemicals are a very serious cause of water pollution.
- **Oil:** All kinds of oils end up in our waterways. Because oil floats on the surface and oil spill can be disastrous for marine life. The oil film can stop oxygen dissolving into the water and can also coat bird feathers or seal fur.
- **Plastic:** Plastic bags and other plastic items are very useful around the home but have disastrous effects on marine life. A great deal of plastic pollution finds its way into the sea through stormwater drains and littering.



2. Water Efficiency

Whether used wisely or wasted, each and every drop of water used is paid for by consumers. By being water conscious in the home, you can help save money on water and electricity bills and assist in protecting the environment.

TAKE WATER WISE ACTION INSIDE THE HOME:

In the kitchen

- To avoid wasting drinking water from a running tap collect it in a bottle or jug and store it.
- Repair dripping taps – one leaking tap can waste more than 500 litres a day.
- Convert to Water Efficiency Labelling Standards (WELS) water appliances such a dishwasher that uses less water at time of replacement.
- Flow controlled aerators for taps are inexpensive and can reduce water flow by 50%.
- Run dishwashers only when fully loaded.
- Don't use running water to defrost frozen water food
- Garbage disposal units use about 6 litres of water per day – put suitable food scraps into a composter or worm farm rather than down the kitchen sink.
- Wash fruit and vegetables in a small amount of water in the sink not under running water.
- Insulate hot water pipes and hot water systems – this will retain the heat longer, and minimise heating units.
- Make sure your hot water system thermostat is not set too high.





In the bathroom

- Turn taps off when cleaning teeth or shaving.
- Check and fix leaking toilets.
- Avoid using the toilet as a wastepaper basket and flushing away tissues as this wastes water.
- Install a water saving shower head. Many showerheads put out 20 litres of water per minute, while 9 litres is actually enough for a refreshing, cleansing shower.
- Take shorter showers. Shorter showers save on energy costs associated with heating water.
- Use a shower timer – choose a 4 minute timer. 4 minutes is sufficient time to completely wash one.
- Use a bucket to collect water while waiting for the shower to get hot.
- Only fill the tub with as much water as needed.
- Regularly check your plug for leaks and replace as necessary.
- Insulate hot water pipes and hot water systems – this will retain the heat longer, and minimise heating units.
- Make sure your hot water system thermostat is not set too high.



In the laundry

- Convert to Water Efficiency Labelling Standards (WELS) water appliances such as washing machines that use less water.
- Run the washing machine only when fully loaded or use the automatic filling level.
- Use the sud-saver option.
- Insulate hot water pipes and hot water systems – this will retain the heat longer, and minimise heating units.
- Make sure your hot water system thermostat is not set too high.

TAKE WATER WISE ACTION OUTSIDE IN THE GARDEN:

- Add a trigger nozzle to the garden hose. You are in control and water is not wasted when moving the hose around.
- Group plants with similar water requirements in the same beds.
- Water the roots and not the leaves. Watering the leaves of trees and shrubs is not beneficial. It just increases water loss through evaporation.
- Water deeply but less often at the right time (early morning or in the evening, not during the hottest part of the day).
- Choose local native and drought resistant plants.
- Use mulch made from bark, leaves, grass clippings or a ground cover on the soil surface to reduce water run-off and evaporation.
- If you want a green lawn toughen the lawn by watering twice a week. Give it feed but don't over fertilise. Aerate the soil and don't mow less than 2cm.
- Avoid wasting water by not allowing automatic irrigation systems to switch on before, during or after rain when the soil is still moist.
- Use a timer with your sprinkler. A forgotten sprinkler wastes more than 1000 litres per hour. A timer will allow you to place as much water as is needed without the threat of wastage.
- Adjust sprinkles so that they do not spray over paths.
- Wash the car on the grass not in the driveway (where the water will run into the stormwater).
- Sweep driveways and paths don't hose them off.





- Cover up the pool when not in use to prevent water loss through evaporation.

3. Rainwater Tanks

More and more households in urban areas are realising what many people in rural areas have known for a long time – that rainwater tanks can provide a renewable supply of natural, and clear water.

HOW SAFE IS RAINWATER TO DRINK?

Provided the rainwater is from a well maintained system, is clear and has little taste or smell, it should be quite safe to drink.

For those at risk of infections or if the water quality is in doubt, it is recommended you boil the water for at least one minute before drinking it or using it for cooking.

Collecting rainwater for drinking and cooking is not recommended in areas affected by airborne pollution from heavy traffic and industrial activities, or agricultural crop dusting or spraying.

Micro-organisms may be present in rainwater collected in domestic tanks, but provided the systems are well maintained, the risk of harmful organisms being present is low.



THE RAINWATER TANK

The provision of good quality water depends on correct design and installation, followed by sensible maintenance of the rainwater tank and catchment area. The collection of rainwater involves ‘low maintenance, but not no maintenance.’

Before buying and installing a rainwater tank, it is advisable to check with your local council to see whether health, building, plumbing or planning regulations applies in the area. This is important if you reside in a reticulated water supply area.

Rainwater tanks are produced in a wide range of materials, all of which are suitable, provided the tank has been manufactured specifically for rainwater collection. The choice depends on your requirements and finances.

Select the appropriate size tank for your needs, consider the cost, whether it is for total or supplementary supply, the amount and pattern of rainfall, roof area and how the water will be used.

Once installed, the tank should be covered and all inspection and access points tightly sealed. It is very important that the inlet and overflow each have a cover, strainer or screen to keep out leaves, debris, animal, bird droppings, and insects, especially mosquitos.

Roofs naturally will collect contaminants and airborne pollution, so installation of a first flush device to divert the first portion of roof runoff is also recommended.

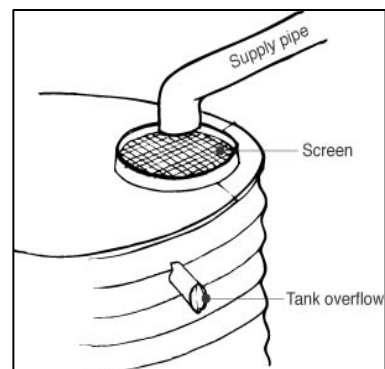



THE ROOF CATCHMENT

Rainwater can be collected from most types of roofs, except those painted with lead-based paint (including primers) or coated with bitumen-based materials.

Chemically treated timbers or lead flashing should not be used in roof catchments and rainwater should not be collected from parts of the roofs incorporating flues from wood burners.

Overflows or discharge pipes from roof-mounted appliances such as evaporative air conditioners or hot water systems should not discharge onto the roof catchment or associated gutters.

MAINTAINING RAINWATER QUALITY

Ensuring the quality of rainwater collected requires sensible maintenance of your rainwater tank and roof catchment. The following simple steps can be taken to help improve rainwater quality.

- Regularly inspect and clean gutters, roof catchments and tank screens.
- Remove overhead branches.
- Consider installing gutter screens or guards.
- Ensure your tank does not become a mosquito breeding site by preventing access and cleaning screens regularly.
- Examine your tank for accumulation of sludge every two to three years and remove by siphon or by emptying the tank.
- If you suspect tank water is contaminated it can be disinfected using 40 millilitres of liquid sodium hypochlorite (12.5 percent available chlorine) or seven grams of granular calcium hypochlorite per 1000 litres of water.

4. How to Read Your Water Meter

Do you know where your water meter is? There are many advantages in knowing where your water meter is. It just might save you a huge water bill before it hits your next rate notice.

WHAT IS A WATER METER?

A water meter is used to measure the amount of water that each property uses.

WHERE IS YOUR WATER METER?

Reading a water meter is really important if you want to save water. But first you need to know where your water meter is located.

Bundaberg Regional Council has installed domestic water meters underground. Generally you can locate your water meter on the footpath along your front boundary either inside a small concrete box and lid or inside a green plastic box and lid. Also along the front boundary aboveground meters can be easily seen.



WHY DO YOU NEED TO KNOW WHERE YOUR WATER METER IS?

It is useful to know where your water meter is because the stop tap or stopcock, which controls the flow of water to your house is also located beside your meter. In an emergency such as a broken water pipe or in need to change a tap washer inside your property, you can use this stop tap or stopcock to turn off the water supply to your house.

READING YOUR WATER METER.

There are several different types of water meters used throughout the region. These water meters appear slightly different to one another but all can be read the same way. The meter measures how much water is used per property in metric. The following details will help you in reading your water meter.

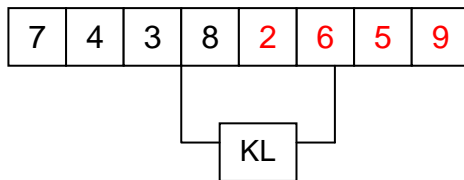

Read from left to right. You only need to read the BLACK figures, which measure kilolitres. Figures in RED represent multiples and fractions of a litre and are used for testing purposes only. The above example shows a reading of 7,438,265.9 litres. For practical purposes, 7438 kilolitres. Black numbers only are read for billing purposes.

Here are two common water meters installed in the city.

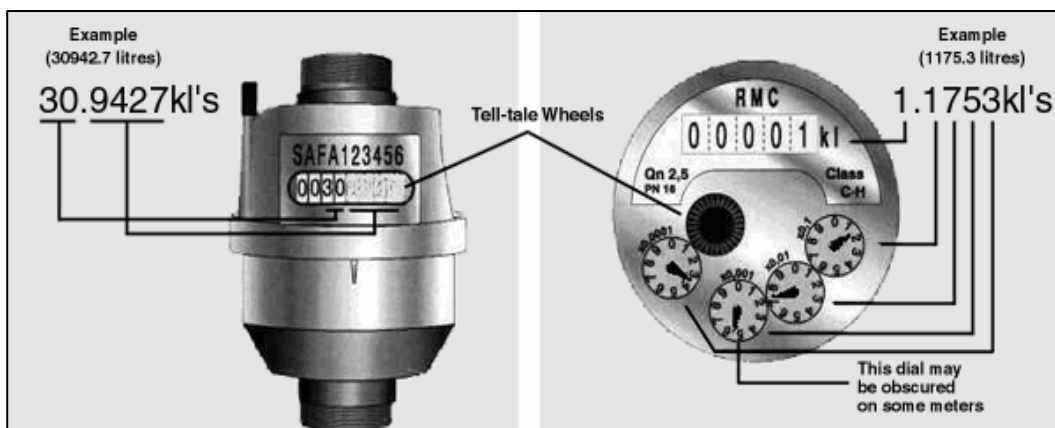

DO YOU HAVE A WATER LEAK?

Your water meter can also help you detect possible leaks inside your property. A simple check involves turning off all taps, including the tap connecting cold water to the hot water system. Check that there are no visible leaks in and around your house and check that the toilet is not filling after a recent flush. Return to the meter and if you see any of the numbers are still recording, this indicates that water is flowing from an outlet on the consumer side of the water service.

This leak may be in a water pipe under the house or under ground or may be a toilet cistern leaking into the pedestal. To check for cistern leaks, put a few drops of food colouring in the cistern, leave it overnight without flushing and if the water in the pedestal is coloured in the morning, there is a leak.



An underground leak may not show up as a green patch in the lawn, depends on weather conditions and soil types. Licensed plumbers are experienced in ways of finding leaks underground. Please note that it is the owner's responsibility to fix water leaks on private property not the Council's.

SAVE A SPARE THOUGHT FOR YOUR WATER METER READER.

It only takes a few moments for us to read your water meter but this simple job is sometimes made difficult when we don't have easy access to the meter.

The Bundaberg Regional Council reads your water meter twice a year and to ensure the best possible outcome there are ways that you can help. The most important benefit is to make sure that the water meter box is visible to the readers by way of removing grass and mulch and pruning overgrown plants around the meter or meter box. Also if you have a dog, keep the dog away from the meter area during reading periods.

5. Pool Maintenance

Maintaining a pool is about more than just turning on a filter and a vacuum. It's a time consuming process involving the checking and adjustment of chemicals on a daily basis.

Pool owners are responsible for the cleanliness of their pool water. If the pool's chlorine, pH levels or other disinfection system are not maintained properly, the chemicals cannot do their job properly. It is therefore crucial for pool owners to regularly adjust chemicals when needed. Pool filters should also be carefully maintained to ensure they are working properly.

There are three types of filters: sand filters, Diatomaceous earth and cartridge. Each collects and removes debris automatically or manually. The easiest being the sand filter which clean by 'backwashing', reversing the flow of water through the filter to loosen the collected debris and sweep into the drainage pipe.

For pools it is important that the water is tested regularly to determine pH, alkalinity and calcium levels. Your local pool shop will be able to assist you in determining the correct levels of chemicals that are needed and testing kits so you can check them.

Pools are breeding ground for bacteria, the main cause being the actual swimmers. Other causes are untreated water from rain, or topping up as well as any debris such as leaves.

Bacteria can cause illnesses ranging from ear, nose and throat infections to serious diseases like meningitis.

The most common way of protecting pools from bacteria is chlorine. There are four ways of administering it: granular, tablet, liquid and via a salt chlorinator. Each method gives the same result, all you need to do is pick a method in line with your budget and lifestyle.



Chlorine kills bacteria by oxidising them. A by-product of the oxidising reaction is chloramines, a half-oxidised pollutant. It is the chloramines that give your pool a chlorine smell, or the stinging sensation in swimmer's eyes indicating a low level of chlorine, not a high one. The way to get rid of and prevent chloramines is to regularly 'superchlorinate' adding three or four times the daily amount of chlorine. It's best done in the evening and staying out of the pool overnight.



Chlorine reacts with the sun's UV rays, but using 'stabilised' chlorine (available in granular and tablet form) will extend its life. Stabilised chlorine is acidic, so will also slowly reduce pH and TA (total alkalinity).

Pool cleaners such as leaf scoops, brushes, automatic vacuum to in-floor cleaners, etc, assist in cleaning the bottom and sides of the pool. They should be used in conjunction with chemicals used to maintain a clean pool.

The water level should never be less than half-way up the skimmer opening. If the level is too low, the pump will begin to suck air, and may burn out. To ensure that water loss isn't too great a pool cover or blanket should be used.

Pool covers and blankets of various types minimise the cooling of the pool by stopping evaporation and heat loss. By creating a barrier between the water surface and the outside air, the losses are minor. Also you save on the cost of chemicals and reduce the amount of chlorine lost in the sun's UV rays. They also keep the debris out of the pool, which reduces the workload of cleaning the pool via the pool cleaner. Most types of automatic pool cleaners will work quite happily under a cover or blanket.



Most pool covers or blankets do not provide protection against children getting into the pool, which may present a hazard. Pool covers should never be considered a substitute for a fence or proper supervision.

Pool fencing must be installed around pools prior to completion. Regularly check gates and fencing to ensure they continue to satisfy the regulations and don't leave any furniture or other items that children can climb on near your pool fence.



During the off season pool owners need to maintain a simple procedure in keeping pools clean and healthy. Don't simply turn the filter off and forget the pool for several months. This is a false economy because the time, effort and money needed to get the pool water correctly adjusted for the next season will be far more than the little needed during the off season.

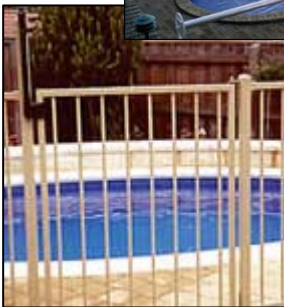

By thoroughly cleaning all your filters/skimmer baskets during the off season, and with the assistance of your local pool shop in stabilising the water consistency, pool owners should only need to check the chlorine level every 2 weeks.

In the Bundaberg Regional Council water area, the backwash from swimming pool filters must be connected to the sewerage system through the sanitary drainage. The overflow is to be connected to the stormwater outlet to allow excess water to flow to the gutter. If the pool is to be emptied for any reason this water is to be pumped slowly into an overflow relief gully on the property.



6. Drip Water Your Garden and Save

How drip watering will save you time, effort and money and our precious water. Drip watering is a modern, effortless, economical way to keep your garden in great condition without wasting time, effort and water.

DRIP WATERING

Drip watering, sometimes called “Drip Irrigation” or “Micro-irrigation”, uses a permanently laid plastic pipe with dripper outlets to deliver the right amount of water to each plant at a rate the soil can readily absorb. Drip watering is effective on trees, shrubs, and some gardens, but is not suitable for lawns, which require an even spread of water.

SAVES WATER

Drip watering puts just the right amount of water right on the ground where your plants will get the full benefit of it. This means it avoids most of the waste you get with other methods of watering.

It delivers water without misting or evaporation and without blowing away. It avoids wastage by supplying water only to those plants to which you have fitted outlets and in volumes you have preset for each and every plant. It delivers water at a rate the soil can absorb; and you can design your drip watering system to suit any size or shape of garden.

SAVES TIME AND EFFORT

With drip watering you save time and effort by not hand watering you garden. Even when sprinklers are permitted, they have to be moved. No more risks from hoses lying on paths or traffic areas.

DRIP WATERING SAVES MONEY

Because drip watering uses less water, it will save your money. Water is expensive to treat. Using less water will help keep rates down. In the longer term, saving water will put off the need to build new headworks which are costly and because drip watering evens out the peak demand. It will reduce the need for extra reticulation work, which is also costly, to meet these demands.

AN APPROVED SYSTEM

A permit is sometimes required from your local Council to install a drip watering system. Permits will only be issued for systems which meet the Specification. The specification is designed to ensure the most effective use of water, minimise waste and reduce peak demand.

SPECIFICATION

1. Only components meeting the requirements of the relevant Australian Standard may be used. Check with your supplier.
2. The system must be turned on manually.
3. The system must be AUTOMATIC SHUT-OFF after the required volume of water has been delivered. This can be achieved by the combination of a Timer and a Pressure Regulator which maintains a constant pressure of 100 kPa (15 p.s.i) in the dripper line independently of mains pressure fluctuations and flow rate. Drippers must have a known and constant flow rate. (If preferred a volume controller may be used in lieu of the timer.)
4. A system should not deliver more than 250 litres per hour through all drippers. If you have a big garden, you may need a second line, but install plastic taps so you don't have to operate both at



the same time. This will minimise the effect that the system will have on your normal household use and for example, the shower pressure will not be affected.

5. The system must be connected to a tap fitted with a hose connected vacuum breaker. The fitting of fertiliser or pesticide injection points to the system is not permitted. These conditions are necessary to prevent possible contamination of the water supply.

BEWARE

When putting in a Drip Watering Kit or designing your own system, some kits on sale do not meet these requirements and would be classed as Sprinklers and not be exempt when restrictions are in force. This would apply also to other forms of micro irrigation, for example, Microsprays. Do not mix micro sprinklers/sprays and drippers on the same irrigation line.

WHAT YOU WILL NEED

For your Drip Watering System, you will need a Timer, a Pressure Regulator, a Filter, Low Pressure Plastic Pipe to take water to your plants, Drippers to let it flow, a tool to install drippers, Plugs to fill holes when you change the placement of a Dripper (or when you make a mistake), Fittings such as Tees and Elbows. Most of these items are inexpensive and readily available.

Timer:- Turns off the water once the system has delivered the preset volume. Avoids waste and overwatering. You will need a timer you can preset up to six hours in areas with clay based soil. You may use a Volume Controller, if you choose but these are more expensive than a timer.

Pressure Regulator:- This lowers the pressure to that needed for the pipe and drippers. To ensure that you preset volume of water is delivered, it will need to be a constant pressure type, rated at 100 kPa.

Filter:- Helps prevent blocked drippers. Essential if the system is to operate effectively. May be incorporated with the pressure regulator.

Low Pressure Pipe:- For home gardeners, 12mm low density black plastic pipe is suitable for carrying water through your system. 19mm pipe may be needed for very long runs. This pipe is not designed to operate at mains pressure. It must be used in conjunction with a pressure regulator.

Drippers:- Drippers come in various forms and flow rates. Your supplier can suggest which kind will best suit your garden. You'll probably need several kinds, so you can fit the right dripper for each plant. Variable flow rate drippers must not be used, in approved systems when permits are required.

Tool to install Dripper:- This makes a simple hole in the low pressure pipe so you can push the dripper in with your finger.

Goof Plugs:- For plugging holes when you decide to move a dripper, or when you make a hole in the wrong place.

Fittings:- Tees, elbows, joiners, connectors and blank ends, so you can assemble a system just right for your garden.

Stop Taps:- Allows you to direct water to plants which require more water while not over watering others.

PLACING THE DRIPPERS

Drip watering is great for trees and shrubs, and some garden beds, but it does not give enough spread of water for lawns and those gardens beds which need all-over watering.



The plastic pipe may be laid on the surface or covered with soil or mulch. It can be buried under your lawn and brought to surface near the base of each tree or shrub. But keep the motor mower clear of it.

Choose and place drippers to give just the right amount of water to each large plant, with spacings to ensure that water reaches part of the root zone of smaller plants. Some roots of most plants extend about the same distance as their foliage, but 90 per cent of the roots are usually within 300 to 500mm of the shrub's trunk.

For larger trees, use several drippers or one which delivers more litres per hour.

The water needs of plants vary with soil, sunlight and wind. But this table is a useful guide for placing drippers, which you may then vary in number and size on the basis of experience.

Diameter at edge of foliage	Dripper
0.5 metres	Share one 2 litre/hour dripper between 2 or 3 plants
1.0 metres	one 2 litre/hour
1.5 metres	one 4 litre/hour
2.0 metres	one 6 litre/hour
2.5 metres	two 6 litre/hour

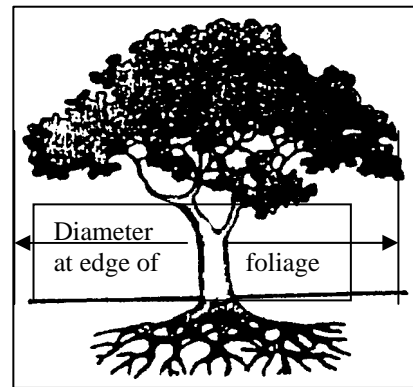

If a large tree overshadows smaller trees or shrubs, calculate the dropper for the large tree only, but make sure a dripper is close to each overshadowed tree or shrub. For this you may need to use several smaller drippers in place of a large one. Instead of two 6 litre per hour drippers, for instance, you could use six 2 litre per hour drippers, for better distribution of the same output of water.

MAINTENANCE

Maintaining your drip watering system is important to keep it operating effectively.

1. Flush the system regularly, particularly after the system has been dormant, to remove unwanted intruders. (They can be an attractive 'home' for ants, insects etc., when not in use for some time.)
2. Check that drippers are not blocked or leaking where they join the plastic pipe.

WHEN TO WATER

Water infrequently and your plants will develop a root system which takes up water at a slow rate. This makes them better able to withstand longer dry periods.

As a guide, water about every four days in warmer weather (three days, if soil is sandy).

- ◆ If 5-10 mm of rain falls, delay watering for one day.
- ◆ If rainfall is greater than 10mm delay watering for four days, but don't delay for more than four days.

Remember this only applies in the warmer months. In the cooler months, watering once or twice per month generally is sufficient.



Some young plants may require extra hand watering until they become established.

HOW MUCH WATER

With drip watering, you will not see the large patches of wet earth (and pathways!) to which you are accustomed. Drip watering puts the water down below the surface, where your plants can use it.

So don't be tempted to over water. It's far easier to kill a plant with too much water than it is with too little.

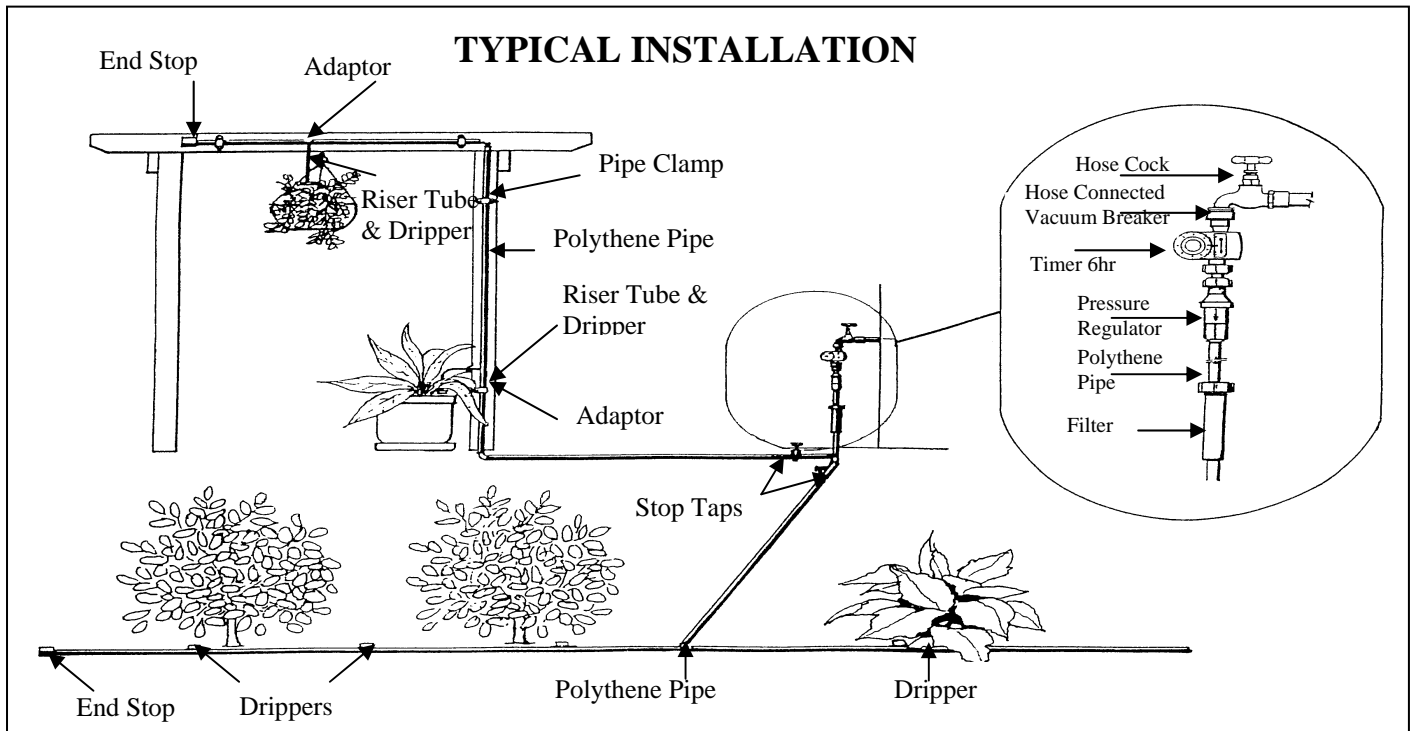

For the best results, give the same amount of water each time you water, and vary the number of days between waterings to suit the weather.

As a guide to calculate how much water for each watering, take the area of the garden to be watered, in square meters and multiply it by 15 to get the volume in litres.

Example, if your trees and shrubs occupy an area of two metres by 50 metres, the area is 100 square metres, the recommended volume is therefore 1500 litres (100 x 15).

You can calculate the time setting on your timer control as follows. Suppose your system has a variety of drippers; 45 two litres per hour, 10 four litres per hour and 20 six litres per hour. This is a total of 250 litres an hour. To deliver the recommended 1500 litres you will need to preset your timer for six hours (1500/250).

IMPORTANT THINGS TO KNOW ABOUT DRIP WATERING

Plants

- Grow to their maximum ability when they receive a regular and consistent amount of water;



- Get the best use of water from that which reaches their feeder roots;
- Drip watering delivers the correct quantity of water to plant roots through the process of osmosis.
- Pressure Regulator, all drip irrigation equipment, low density pipe, emitters etc, are rated at 100 kPa (15 psi);
- The low pressure preserves the life of components through less stress, and provides a correctly designed constant pressure system that will have little effect on the normal operation of the house-work water usage;
- It is important to realise that Pressure Reducers are NOT to be used as they are not regulators and reduce pressure by a percentage of the original;
- Low pressure results in less likelihood of components blowing out and in the event of a blowout, water loss will be minimal due to the combination of low pressure and the timer.

Soil Wetting Patterns

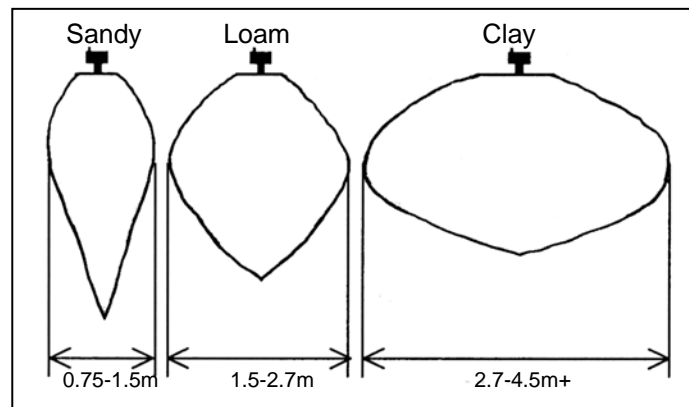

- System components, (regulators etc.) are rated at a given maximum flow rate, generally 250 litres per second. As an example this would allow for 125 x 2 litres/hour drippers in use at the one time. Where more watering was required, the system would be divided into branches each controlled by a plastic in-line tap and each having 250 litres/hour flow or less;
- Regular removal of end caps and flushing ensures a trouble free watering system;
- All systems require a form of backflow prevention to protect the normal water supply from possible contamination. A hose connected vacuum breaker is sufficient in a normal house situation however the law demands a testable medium hazard device, usually a double check valve (DCV) for greater protection in all properties other than houses.

Rule of Thumb

- Many formulae exist that will work out the water requirements for individual plants however for a simple rule of thumb use the table provided (based on one 2 litre/hour dripper for a 1 meter diameter Australian native);



Soil	Time on	Period between watering	Season
Sandy	2 hours	1 to 2 days	Summer
		3 to 4 days	Autumn/Spring
		Once/week	Winter
Loam (Normal)	4 hours	3 to 4 days	Summer
		Once/week	Autumn/Spring
		Once/ 2 weeks	Winter
Clay	6 hours	Once/week	Summer
		Once/ 2 weeks	Autumn/Spring
		Once/month	Winter

- Water in sandy soils penetrates quickly and deeply (like a carrot) but also dissipates quickly, therefore water for short periods of time but frequently;
- Water in loamy soils penetrates and dissipates over a longer period of time and a cross section would look like an onion;
- Water in clay soils takes a very long time to get down to the root zone and a long time to leave the root zone hence water for long periods but infrequently. The cross section would look like a pancake. Apply water at a slow application rate to prevent ponding and run-off;
- Fully grown trees do not need watering at all, their roots usually gather enough moisture from the soil without assistance; and
- More plants die by being over-watered than do by being under-watered.

7. Water Audit for the Household

WATER AUDIT

Water is the most precious natural resource we have yet we often take it for granted.

This simple audit is designed to help you work out approximately how much water you use and where in your household you use most of it.

By cutting down the amount of water you use, you'll be helping the environment, saving yourself money as well as helping our water supply system.

So, let's get started. Grab a pen and calculator and see how much water your household uses. You may be surprised at the results and how easy it is to use water more efficiently



	No. of persons in household	No. of uses per person per day	Volume of water per use	
Toilet				
Shower				
Bath				
Cleaning Teeth				
Washing Hands				
Washing Dishes				
Dishwasher				
Drinking				
Washing Machine				
Washing Cars				
Washing Pets				
Watering Gardens etc				
Hosing Driveway				
Dripping Taps/Leaks				
TOTAL				

VOLUME GUIDE - To work out the volume of water used in your water audit, here is a guide.

<i>TOILET – Full flush (old)</i>	<i>12L</i>
<i>Full flush (dual)</i>	<i>6L</i>
<i>Half flush (dual)</i>	<i>3L</i>
<i>SHOWER – Water saving rose head</i>	<i>8L/min</i>
<i>Older Style rose head</i>	<i>20L/min</i>
<i>BATH – Quarter full</i>	<i>30L</i>
<i>Half Full</i>	<i>60L</i>
<i>Full</i>	<i>120L</i>
<i>CLEANING TEETH – Tap running</i>	<i>5L</i>
<i>Tap turned off</i>	<i>1L</i>
<i>WASHING HANDS</i>	<i>4L</i>
<i>WASHING DISHES – Full sink</i>	<i>18L</i>
<i>Half sink</i>	<i>7L</i>
<i>DISHWASHER – Fast cycle</i>	<i>15L</i>
<i>Normal cycle</i>	<i>20L</i>
<i>DRINKING – 5 glasses</i>	<i>1L</i>
<i>WASHING MACHINE – Top loader</i>	<i>200L</i>
<i>Front loader</i>	<i>50L</i>
<i>WASHING CARS – with a hose</i>	<i>100/300L/wash</i>
<i>WASHING PETS</i>	<i>50L</i>
<i>WATERING GARDEN/LAWNS</i>	<i>1000L/hour</i>
<i>HOSING THE DRIVEWAY</i>	<i>75L/wash</i>
<i>DRIPPING TAPS OR LEAKING TOILETS</i>	
<i>3 drops per second is approximately</i>	<i>65L/day</i>

Bundaberg Regional Council
Infrastructure Services'
1300 883 699



BUNDABERG
REGIONAL COUNCIL

ANOTHER
PUBLIC AWARENESS INITIATIVE

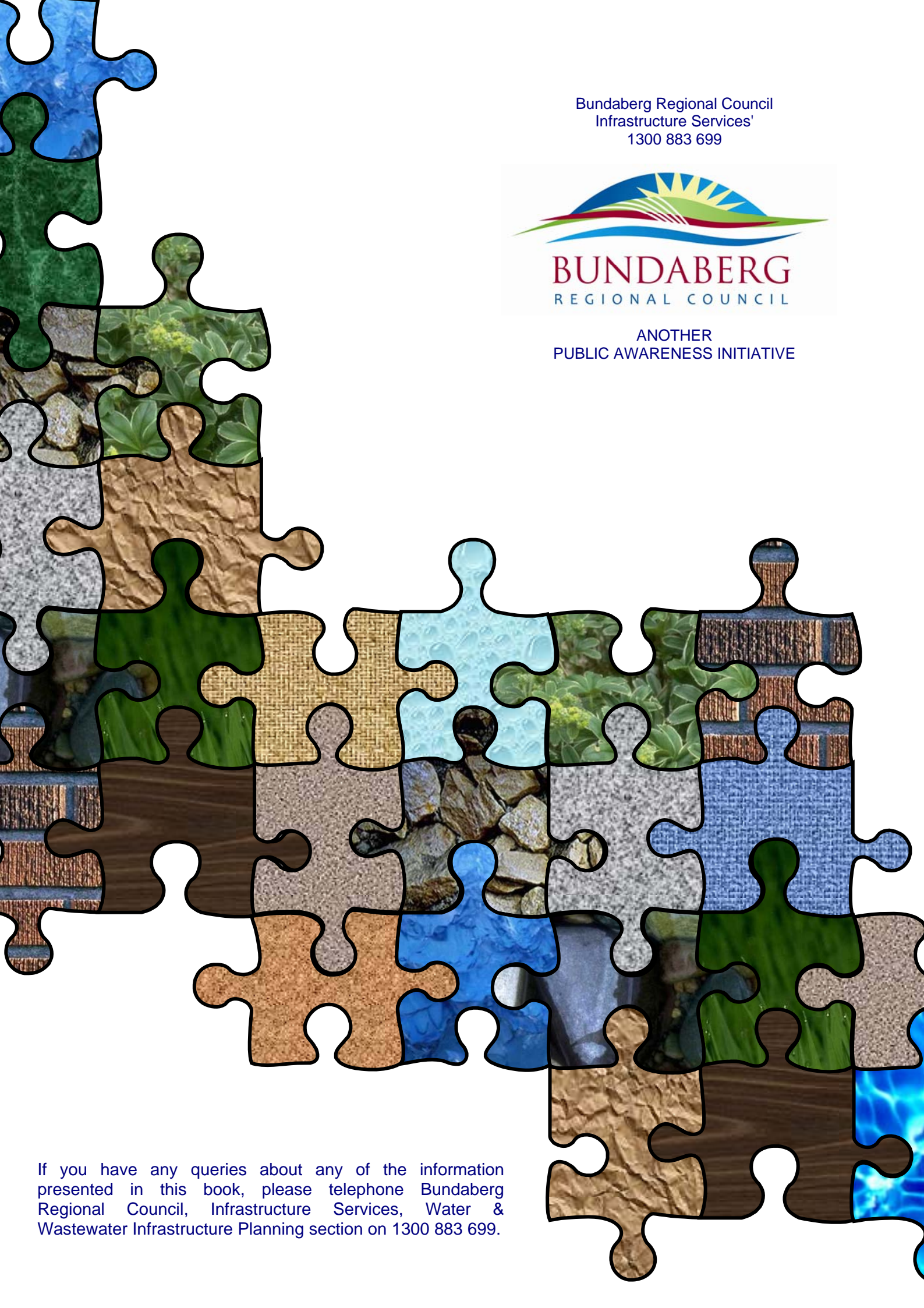

If you have any queries about any of the information presented in this book, please telephone Bundaberg Regional Council, Infrastructure Services, Water & Wastewater Infrastructure Planning section on 1300 883 699.